

Home Owner's

OPERATING INSTRUCTIONS

Do Not Discard!

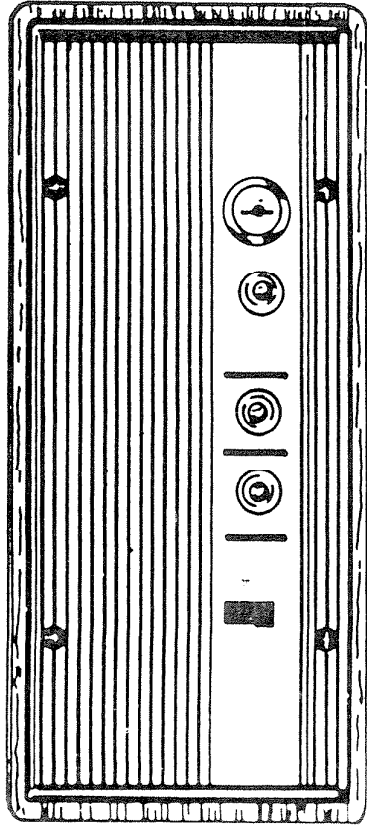

Household Burglary Warning System Control Unit.

The SB-2253 is designed for one major purpose: to make you aware of an unwanted intrusion onto your premises. Intruder protection for your family and home begins with two basic steps: (1) know how to take full advantage of the security provided by your NuTone Intruder Alarm System and (2) establish a family safety program in which you and your family will practice sound intruder prevention techniques. This manual contains important operating instructions as well as some common-sense ideas about a family safety program. Take a few minutes now to read this booklet. Learning how this system operates can help you and your family create a more secure home.

NuTone Intruder Alarm System

MODEL SB-2253

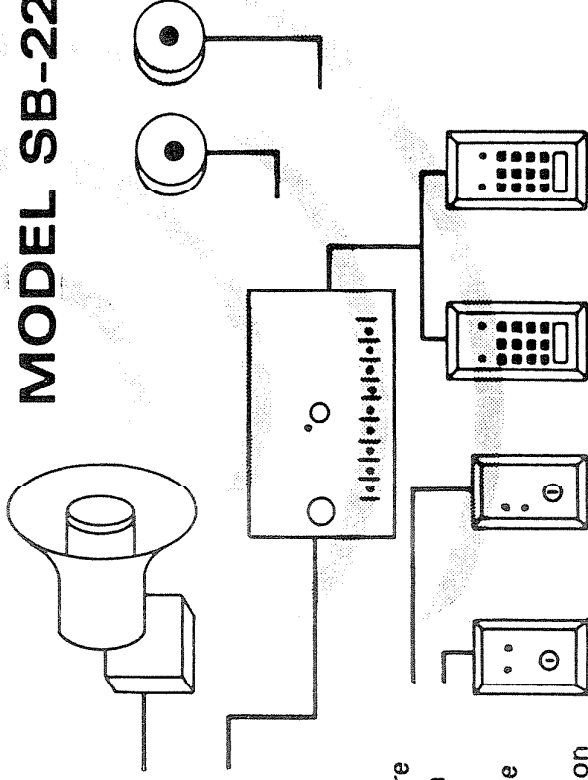

Contents

Control Panel Components.....	3
Control Unit Components Behind Panel.....	4
Indoor-Outdoor Remote Panels.....	5
Exit-Entry Time Delay Circuit.....	6
Interior Control.....	7
Testing.....	8
Family Safety Program.....	9
Optional Accessory Switches.....	10
Interior Detectors.....	11
Rechargeable Battery and Battery Replacement.....	12
Fuses.....	13
Indicators Checklist.....	14
Warranty.....	16

Panel Key No.: _____ Date Installed: _____

By: _____ Phone Number: _____

Control Panel Components

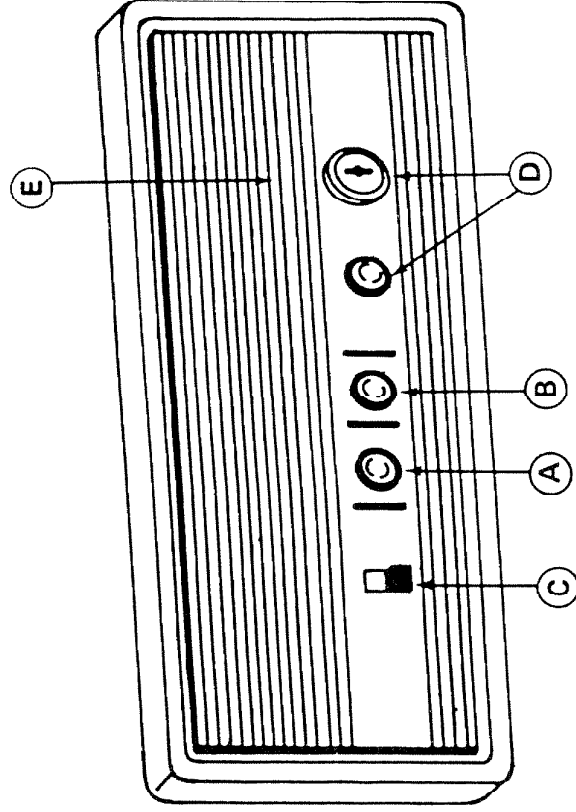

Model SB-2253 Control Panel contains: indicator lights (LED's) which allow you to monitor the system; a key switch for arming and disarming the system; an on/off switch for controlling the Exit-Entry Time Delay; and a warning buzzer.

(A) AC Pilot Light. When lit, your house's electrical system is supplying power, through the plug-in transformer, to the Control Unit.

(B) System Not Secured (Trouble Indicator). When lit, an intruder detector is activated (i.e., window open, door ajar). The System cannot be armed until all detectors are secured.

(C) Timed Exit-Entry Switch. This switch controls the perimeter and interior detection loops. In the UP position this switch allows up to 60 seconds to exit and up to 45 seconds alarm delay during entry. In the down position, the alarm will instantly sound when a detector activates. Flip the switch to "instant" at night when everyone is home and no more exits and entries are expected.

(D) Key Switch. Resets, arms, and disarms the system. Green light marked "System Armed" will be lit when system is armed. (Key switch purchased separately.)

(E) Buzzer. Located behind panel. The buzzer sounds during entry delay and then stops during alarm; it sounds again after alarm automatically shuts down. Silence buzzer by resetting system with keyswitch.

(F) Interior Control (not shown). If you have Interior Protection, it is turn on — "ready to be armed" — by one switch (S-2285 or S-2286, page 10) located elsewhere. You arm Interior Protection from only one location. See also: "(B) Yellow Light," page 5 and "Interior Control," page 7.

Control Unit Components Behind Panel

CAUTION: DISCONNECT POWER BEFORE REPLACING FUSES.

To gain entry to these controls:

Remove the four screws. Gently pull the panel forward, just enough for access to the item you need. Tilt the bottom of the panel upward so you are facing the adjustment dials. To replace, carefully push wires back into the box and up into wall opening. Fix in place with four screws. (See also: "Battery Replacement," page 12.)

Alarm Time Adjustment (4 to 12 minutes) To increase time, turn clockwise. The alarm sounds for length of time set by this control, and then automatically shuts off. The buzzer begins sounding after alarm shuts down to notify owner that alarm has sounded. See page 12 for alarm time on battery power.

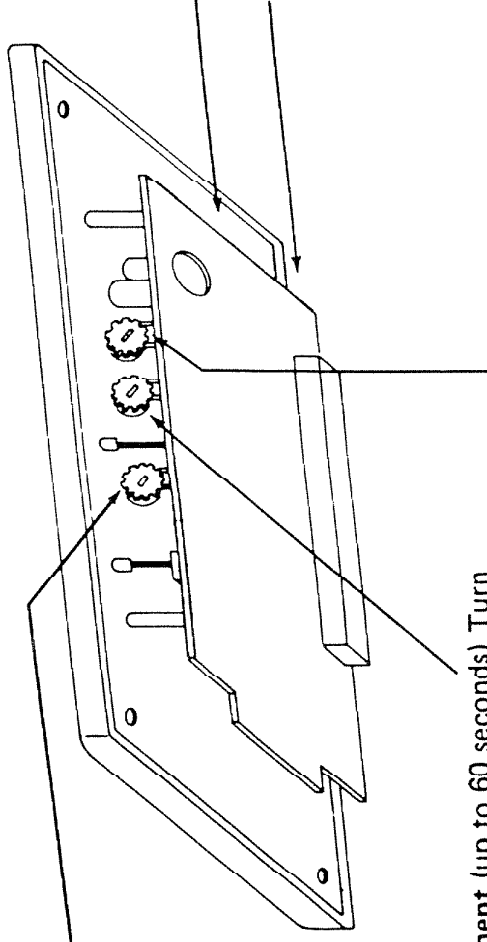

Disconnect battery leads before changing fuses.

Battery Fuse. F2, 2 Amp, 250V. Remove fuse by prying loose with ball point pen.

Auxiliary Power Fuse. F1, 1 Amp, 250V. Remove fuse by prying loose with ball point pen.

Locate fuses on inside of panel.

Exit Time Adjustment (up to 60 seconds) Turn clockwise to increase time. After arming system, this control provides the time to exit and close the door without causing an alarm. **Do not set for more time than you need. Do not set over 60 seconds for any reason.**

Entry Time Adjustment up to 45 seconds) Turn clockwise to increase time. After entering the protected area, this control provides the warning time (buzzer sounds) to reset system and avoid unwanted alarm. **Do not set for more time than you need. Do not set over 45 seconds for any reason.**

Indoor - Outdoor Remote Controls

Model SA-2226 and SA-2227 Remote Controls, optional accessories, are located at every exit/entry door to arm and disarm the system when leaving and entering the house.

(A) **Green Light.** When lit, it shows the system is armed. If it doesn't light when you try to arm the system, a detector is activated: check the red "System Not Secure" light on the Control Unit.

(B) **Yellow Light.** This indicates whether the Interior circuit is "ready to be armed." It does not mean the Interior circuit is armed or disarmed. Both the yellow and green lights will be lit when the Interior circuit is armed. If only the green light is lit, then only the perimeter circuits are armed. See "Interior Control," page 7. If not used as Interior indicator, the yellow light may be used as a "System Not Secured" indicator — see "B" page 3.

(C) **Red Light.** It is lit under the following conditions: (1) during timed entry; (2) after alarm has sounded and shut down. It turns off when system is reset with key switch. (If you return home and find the red light on an SA-2226 control lit, it may be unsafe to enter the home.) The red light is never lit when the system is disarmed.

(D) **Key Switch SB-2225.** Resets, arms, and disarms the system. Not included as part of SB-2253, SA-2226, or SA-2227. Purchased separately so that all keys in the system can be matched. See page 15 for important information about SB-2225 Key Switch.

(E) **Buzzer.** Located behind the SA-2227 cover, it sounds when the red light (C) is lit and under the same conditions.

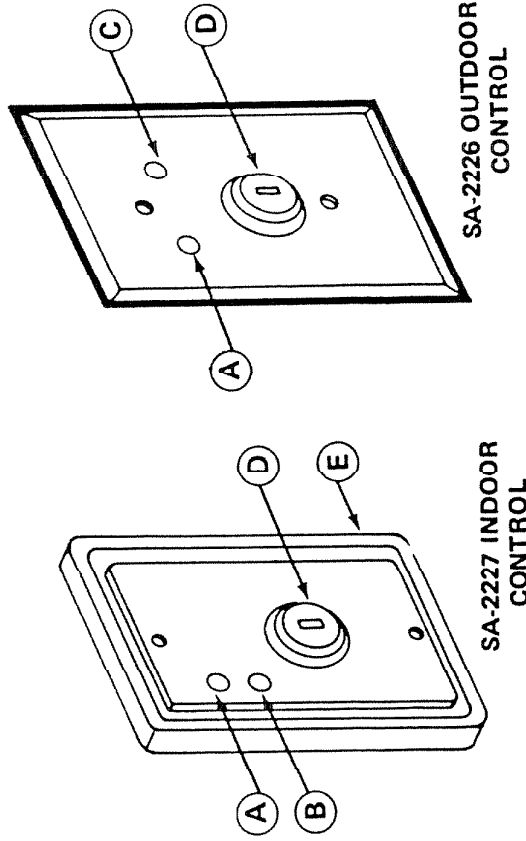

* May also use SA-2227 and SA-2226 Remote Controls.

Exit - Entry Time Delay Circuit

The SB-2253 system uses a Timed Exit-Entry door circuit. This circuit's built-in time delay allows you up to 60 seconds to exit the house after you have armed the system. Upon entering the house, you have up to 45 seconds to reset the system to prevent an alarm from sounding. During the entry, a buzzer in the indoor remotes and in the Control Panel will sound continuously, warning you to reset the system.

Normally you will protect only two or three of your most frequently used doors with this time delay. Inside, you will usually have the SB-2253 Control Panel or an indoor remote keyswitch located closely to the exit/entry door.

Simply put, the time delay has two cycles: (1) the exit timing cycle (60 seconds), which is started as soon as you arm the system; and (2) the entry timing cycle (45 seconds), which begins after the exit time is completed if the door remains open or when the door is reopened.

Picture This Example: You have tried several time delay adjustments, and now you've decided that 30 seconds is enough time to exit the house and that 40 seconds is enough time to enter.

When you are leaving the house, you arm the system by turning the key in the keyswitch. If the system is already armed, you disarm it by turning the key once, and then turn the key again to re-arm it. This gives you the complete 30 seconds exit time. As soon as you arm the system, the exit timing cycle begins. You must now open the door, leave, and close the door within 30 seconds. The exit cycle will complete its time, and then the system will automatically switch over to the entry timing mode. If you don't exit in time, the warning buzzer and outdoor red LED which accompany the entry timing cycle will sound or light — you must return to the keyswitch, reset the system, and exit again.

Later, you return home and enter the house. As soon as you open the door, the entry timing cycle begins. You will hear the buzzer sounding and you must reset the system before the 40 seconds elapse. If you don't reset the system, the entry cycle will complete its time and an alarm will immediately sound.

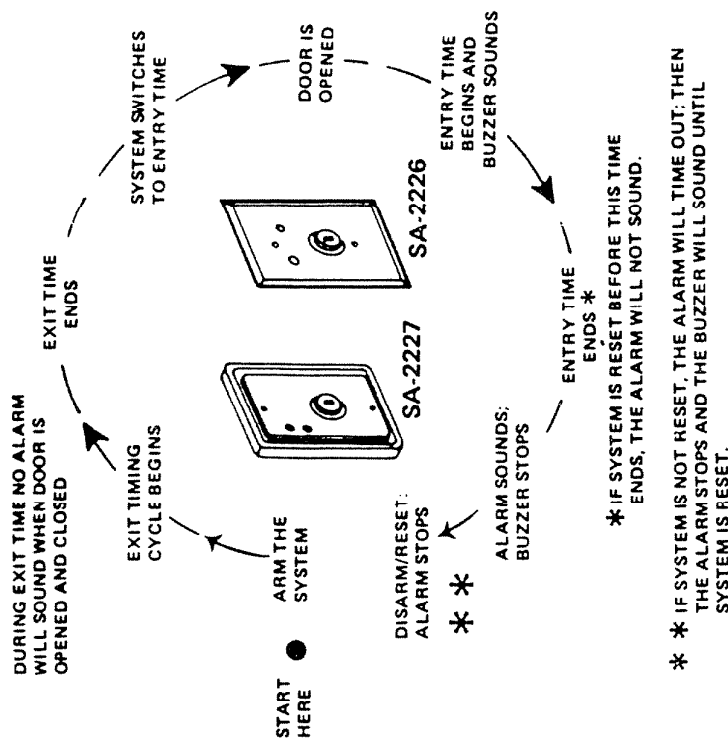

Indoor and Outdoor Remote Panel Key Switches. If you use both indoor and outdoor controls, the exit-entry procedure is easier. Exit and enter the house by disarming the system before opening the door, and then re-arm the system after closing the door. Before departing, test the system to be sure it will arm. (See page 7, "Interior Control.")

NOTE: If the green light does not light when you try to arm the system, one or more of the detectors is not properly secured. Check to see that all doors and other detectors are in secured positions.

Interior Control

SB-2253
Control Unit

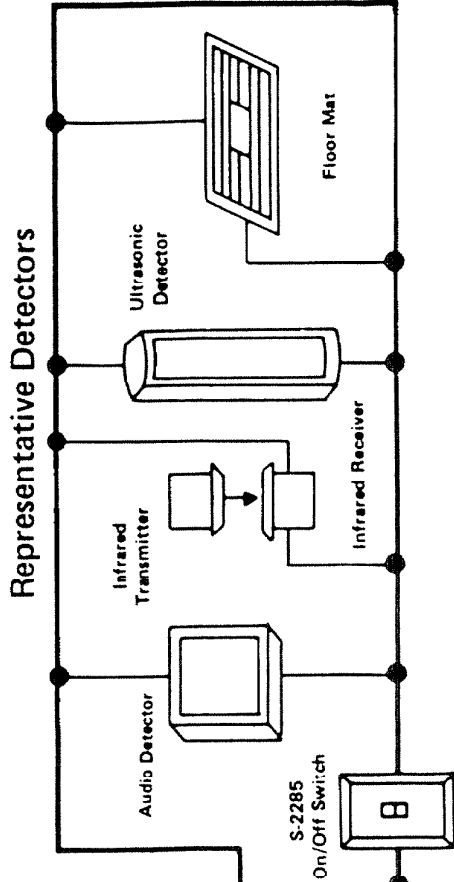
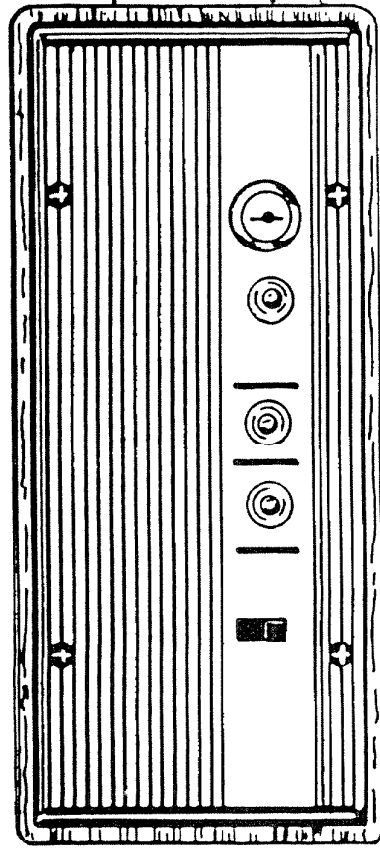

If you have Interior Protection, you want it to detect an intruder when you are asleep or away from home. When you are up and moving about the house, you may want your perimeter circuit armed but your Interior circuit turned OFF. This will allow you to move about inside the house without sounding an alarm when the system is armed.

As with the perimeter, the Interior Protection Circuit is subject to the Exit-Entry delay. Since this switch, found on the Control Panel, is only for delay or an instant alarm, it is necessary to control the Interior Circuit by an ON/OFF toggle-style switch (S-2285 or S-2286, page 10). Flipping this switch to ON puts the Interior Circuit in its "ready to be armed" mode. The Interior Circuit must be in this mode before it can be armed; and it can only be armed when the perimeter circuit is armed. The Interior cannot be independently armed.

If the system is already armed, turning this switch ON will, in effect, arm the Interior detectors. At this point, if an Interior detector is not secure, you will sound an alarm. Therefore, be sure to disarm the system before turning the Interior ON. After you've turned ON the Interior, check your Trouble Indicator.

Then, if the Trouble Indicator shows that no Interior Detector is activated, you can arm the system. Remember to always turn on the Interior Circuit when system is OFF to prevent unwanted alarms.

When everyone has retired and no more movement in protected areas of the house is expected, turn the Interior ON. The yellow lights on your Indoor Controls will light when the Interior is ON. See "(B) Yellow Light," page 5.

If you need to get up during the night and pass through a protected area, turn the Interior OFF. The perimeter will remain armed. Turn the Interior back ON when you return to bed.

Testing

Regularly test the system once each week. (Note: Your system may not include all the items mentioned in testing procedure.)

System Test

1. Close all doors and windows; secure all detectors so that red light "System Not Secured" goes out.
2. If you have an Interior Control switch, flip it to ON. The yellow lights on the Indoor Remote Controls should light. If red light "System Not Secured" on Control Unit lights, an interior detector needs to be secured.
3. Flip the Timed Exit/Entry switch to UP (Timed Exit/Entry Position).
4. Arm the system with a keyswitch. This begins the exit time period.
5. Open an entry door. The red light on the SB-2253 Control Unit should light while door is open.
6. For up to 60 seconds (see page 6) during this exit time period nothing else happens.
7. With the door still open, when the exit time elapses, the buzzers in the SB-2253 and SA-2227 and the red light on the SA-2226 outdoor control activate for a time up to 45 seconds (see page 6). Check every one of these installed units for sound or light. This is the entry time delay period before an alarm sounds.
8. After the entry delay expires, the alarm should sound. The entry indicators stop. Close the door. Check every alarm device for sound.
9. Reset the system, using one of the keyswitches. Alarms stop sounding.

8.

10. Flip the Timed Exit-Entry Switch down to "instant." Arm the system with a key switch. Open a door.
11. The alarm activates immediately.
12. Close the door and reset the system. All indicators cease.
13. Test all other detectors, both interior and perimeter, in the same manner by repeating 10 thru 12.
14. Disarm the system and test Emergency switch. The alarm should sound instantly. Test all emergency switches. **NOTE:** When the emergency alarm is activated, the system automatically becomes armed. It will disarm when the emergency alarm is reset.

Battery Test (For Systems using battery back-up)

When AC power is lost, the security system operates under battery power. This test checks battery operation.

1. Turn off the house circuit breaker that controls the power supply to the security system. (An alternative to turning off the Circuit Breaker is to remove transformer from wall outlet while performing the Battery Test; replace transformer with screw when test is concluded.) The green "AC Power" light goes out on the Control Panel.
2. With the Timed Exit-Entry switched to "Instant," arm the system.
3. Open an entry door. Alarm should sound instantly. Reset system.
4. Turn on the circuit breaker. The green "AC Power" light turns on.

IF YOUR SYSTEM DOES NOT OPERATE PROPERLY IN ANY OF THE ABOVE TESTS, SEE SECTION ON "FUSE REPLACEMENT." (Refer to page 13).

Family Safety Program

Your family should know and practice intruder prevention techniques and follow a safety program.

1. Be sure all access to your house is secured against intruder entry. This includes not only ground-level windows and doors, but also garage doors, basement windows, windows accessible from balcony, porch or garage roof, trees, etc. Always lock your doors and windows. Even if you are leaving for only a short time, lock your door.
2. Do not give notice of your absence. When you are not going to be home, take the following precautions: leave a few blinds and drapes open as if you were home; use electric timers to activate lights and radios; when you will be away for a long time, have your mail picked up by a neighbor (or have the post office hold it); stop all other regular deliveries; have someone take care of your yard.

3. Make sure your door locks are in good condition. The latch or bolt of the lock should extend at least 5/8" into the door jamb. Replace old locks with mortise or deadbolt locks. Have locks re-keyed if you have recently moved into a new apartment or house. Have locks rekeyed if a set of keys have been lost along with any identification cards. Check condition of doors: they should be solid, fit flush to jamb, and have strong frames.

4. See your hardware store or locksmith for inside key locks for windows and sliding glass doors.
5. Be wary of strangers at your door or on your phone. Ask to see credentials of persons representing companies. If strangers wish to use your phone, offer to make the call for them.
6. **What to do when an alarm sounds.** If an alarm sounds during the night, you should assume it is not a false alarm. Most police departments recommend that you let the alarm continue to sound and that you stay where you are and immediately call the police. Wait until the police arrive before you leave your bedroom.

Optional Accessory Switches

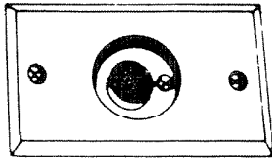

MODEL SA-2270 EMERGENCY PUSHBUTTON

The Emergency Pushbutton is wired to a special circuit so that its armed status is not controlled by the key switches. As long as the security system has power (from household current or standby battery), the Emergency circuit is armed at all times. Simply pressing the SA-2270 pushbutton will cause an instant alarm. Following use of Emergency pushbutton, the system is reset with the key switch controls.

MODEL S-2285 & S-2286 ON/OFF SWITCHES

These on/off switches are used for two purposes. First, they are used to control a specific entry detector. When switched on, you can bypass the entry detector — allowing you to open a window or door, or to pass through a protected interior area. Second, one of these switches can be used to control the entire Interior Circuit. See page 7, "Interior Control."

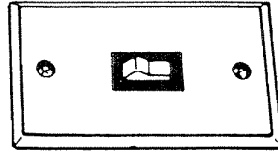

S-2286

WARNING: Do not leave this switch in the ON (bypass) position indefinitely. Doing so will prevent the alarm from sounding if a bypassed detector is activated. Although the system can be armed with the bypass switch ON, the alarm will not sound when bypassed detector is activated.

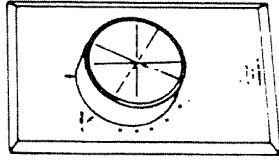

S-103 & S-2282

INDOOR TIMER SWITCHES

The timer switches are used to control specific detectors. By activating the timer, you may open a window or door, or pass through a protected interior area without causing an alarm. After the timer completes its cycle, the detector is automatically rearmed, (60 seconds). If the SB-2253 exit/entry time delay is not used, these indoor timer switches are used in conjunction with outdoor timer switches (see below).

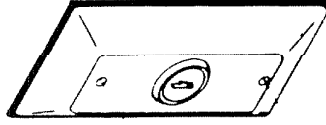

S-102 & S-2281 OUTDOOR KEY-OPERATED TIMER SWITCH

Used outdoors to bypass an entry detector on a door. Activating the timer will allow you to enter the house without causing an alarm (30-second timer). These switches are used if the user does not use the SB-2253 built-in exit/entry time delay.

OPTIONAL ACCESSORIES

If you plan to use the S-2386 Digital Communicator or the SB-2376 Automatic Telephone Dialer, refer to those Operator's Manuals for use with the SB-2253 Intruder Alarm System.

Intruder Detectors

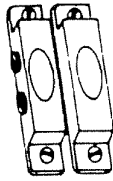

MAGNETIC SWITCHES — Magnetic switches consist of two sections: the electrical switch and magnet. The magnet activates the switch — when it is removed from the switch, a contact is opened (or closed) which triggers the alarm.

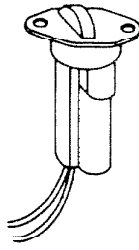

ROLLER/PLUNGER ENTRY DETECTORS — Used to protect doors only, these detectors are activated by a door depressing or releasing the roller/plunger. Models available for use in both open and closed loop detection circuits.

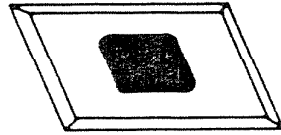

PHOTOELECTRIC DETECTOR — The photoelectric detector consists of two sections: one section sends an infrared beam to the other section. If that beam is interrupted, the detector triggers the alarm.

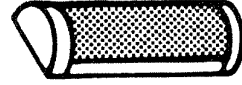

ULTRASONIC MOTION DETECTOR — The ultrasonic motion detector protects an area by setting up a field of inaudible sound waves. If an intruder moves through the protected area, he will cause a change in the frequency of the reflected sound waves and thus trigger an alarm.

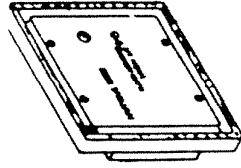

AUDIO DETECTOR — The audio detector is designed to sense the sounds of splintering wood or shattering glass. Upon sensing the sound, the alarm is triggered.

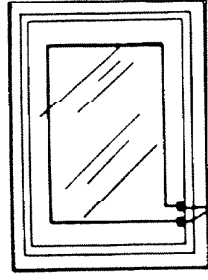

WINDOW FOIL — Window foil is part of the electrical circuit in a perimeter protection circuit. If it is broken, the circuit will be interrupted which will cause the alarm.

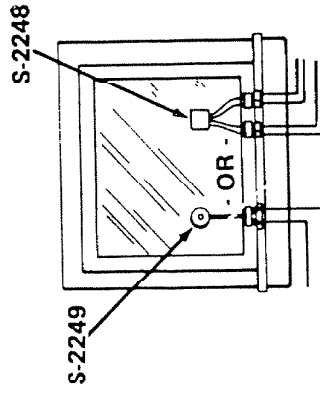

GLASS-BREAK DETECTORS — Glass-break detectors are designed to detect vibrations or frequencies within glass when the window to which it is attached is broken or cut. Once each week, test the glass-break detector with NuFore Model S-2249T Tester or with I.E.T. 712 Tester for S-2248 (see S-2248 Installation Instructions).

FLOOR MATS — A floor mat switch is activated by pressure. If an intruder steps on a concealed floor mat, he will activate the switch and cause an alarm.

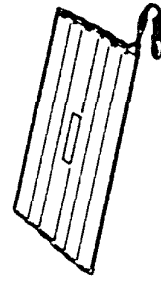

PASSIVE INFRARED DETECTOR — A Passive Infrared Detector triggers an alarm when it detects a change in temperature accompanied by motion in the detector's field of view.

The Rechargeable Battery

The S-2372 Rechargeable Battery provides three to five years of non-continuous standby operating power. Whenever necessary, the Control Unit's built-in battery charging circuit will automatically recharge the battery.

The battery should be replaced if you notice the following signs during a battery test (page 8):

(1) alarms are not as loud as in previous tests; or (2) alarm sounds are erratic or inconsistent.

If a replacement battery is required, use NuTone S-2372. For the name of your nearest NuTone Sales Outlet, dial NuTone, toll free, at 1-800-543-8687

CAUTION: Although not required for operation, this battery is strongly recommended for use with your SB-2253 Intruder Alarm System, especially if your Electric Meter is outside the protected area.

WARNING: USE ONLY RECHARGEABLE BATTERY!

Battery Replacement

To replace the battery:

1. Remove four screws from Control Unit's front panel. Gently lift the panel out of the way without disconnecting the wires.
2. With battery wires still connected, raise the battery out of its pocket by lifting the wires at the battery terminals. Remove the sockets from the terminals.

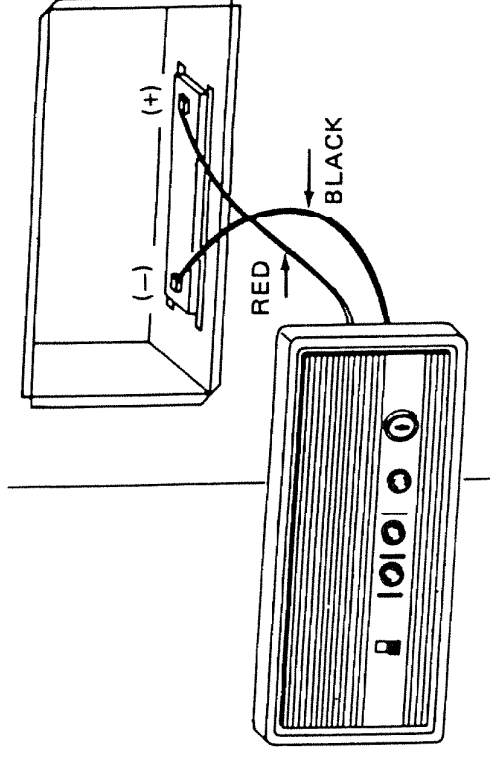

3. With the red (+) terminal to the right, place the new battery into the pocket. To prevent short circuit, make sure the battery's graphics are facing the rear.
4. Connect the battery sockets to the new battery: Red to positive (+); Black to negative (-). Seat them fully.
5. Carefully place wires into the housing and secure the front panel.

Battery Performance: When AC house power is lost, a fully charged battery will provide a minimum of 5.5 hours stand-by protection followed by at least 4 minutes of alarm time.

CAUTION: When installing a new battery, be especially careful to reconnect each wire to its proper terminal. Fully-charged batteries can deliver enough current to melt wires. The voltage (12 volts) does not present a shock hazard; however, improper connections will cause the battery fuse to blow.

Fuse Replacement

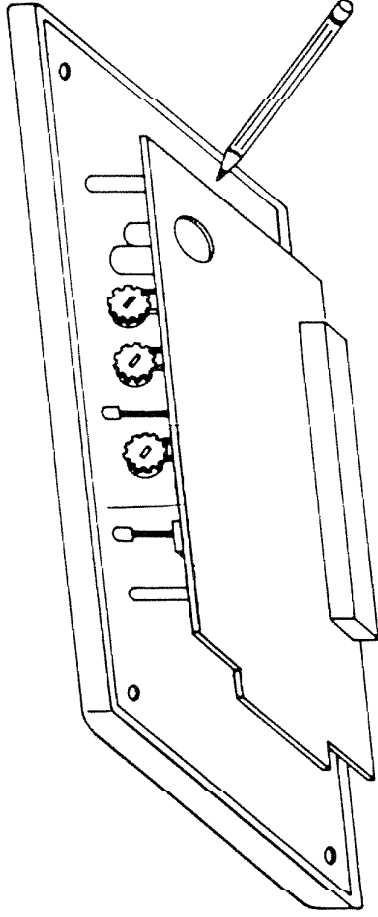

Remove fuse by prying loose with ball point pen
Locate fuses on inside of panel.

Indication of Blown Fuse	Fuse	Probable Cause
During Battery Test: no alarm, no indicator lights.	F2, 2 Amp, 250v Bussman AGC2 or equal (1/4" x 1-1/4").	Overload on alarm terminals 11 to 12, or momentary short circuit. Reversal of battery wires.
System will not arm, disarm, or reset. Remote Control indicator lights do not light.	F1, 1 Amp, 250v Bussman AGX-1 or Littelfuse No. 362001 (1/4" x 1").	Overload on Auxiliary power terminals 3 to 4, or momentary short circuit.

CAUTION: Before changing fuses, turn off AC power and disconnect red (+) battery wire.

IMPORTANT: After changing battery or fuses and whenever the panel has been replaced, the system should be completely tested for both AC power and battery operation. See page 8.

Indicators Check List

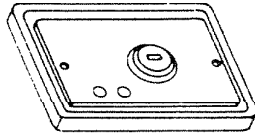

SA-2227

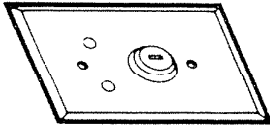

SA-2226

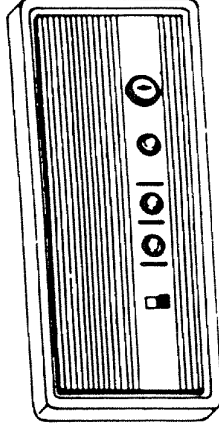

SB-2253

Indication	Cause	Probable Remedy
Continuous buzzer sound in SB-2253 Panel and SA-2227 Remote Control.	Sounds during timed entry and after alarm automatically shuts down.	Reset system with key switch: buzzers stop and lights go out.
Red light on outdoor SA-2226 lights.	Lights under same conditions as above.	See above.
Bell, siren or horn sound.	Sound during alarm condition.	Reset system with key switch: alarms should stop.
System won't arm. Red light on Control Panel is lit.	System Not Secured.	Check for open door, window, or other unsecure detectors.
Green "AC Power" light is OFF on Control Panel.	AC power is lost.	Reset house circuit breaker; check for loose wire connection or defective transformer.
Green "System Armed" light or green light on Remote Control are lit.	Lit when armed. Unlit when not armed.	Use key switch to change condition.
Yellow light on indoor SA-2227 is lit.	<ol style="list-style-type: none"> Interior arming switch is on. System not secured. (See "B" page 5.) 	<ol style="list-style-type: none"> Turn switch off if interior protection is not wanted. Door or other detector not secured. (See "B" page 5.)

SB-2225 Key Switches: Important User Information

The SB-2225 Key Switches are high security switches. For this reason, the key code number is **not** stamped on the keys or on the switch itself. Two keys on a ring are provided with each key switch; the key code number is printed on a tag attached to the ring. **The Security System user should keep this tag in a safety deposit box or some other safe place.**

The SB-2225 Key Switch is available in over 5000 possible key codes. Standard packaging is 3 to a pack keyed alike with each lock having 2 keys provided.

If additional matching keys or lock cylinders are required, they can be purchased through your local NuTone distributor. You should indicate the key code desired at the time you place your order.